

**Our associates will ensure the tool works properly before you leave the store. If you experience issues with the tool while completing your project, simply bring it back to the Tool Rental Center to get a replacement. If you purchase Damage Protection at the time of your rental, you are not responsible for repair costs for tools that break due to normal use.**





**PROPANE TORCH KITS**

**Please Read and Follow All Instructions and Save These Instructions For Future Reference.**

• This device is intended for outdoor use only.

• This torch is designed for a vapor-withdrawal LP-Gas cylinder only.

**Operating Instructions and Parts Manual For Models:**



Model	BTU	P.S.I.	Normal
VT 3-30 C	500,000	5-90 P.S.I.	30 P.S.I.
VT 2½-30 C	400,000	5-90 P.S.I.	25 P.S.I.
VT 2½-24 CE	500,000	5-90 P.S.I.	30 P.S.I.
BP 2512 C	400,000	5-90 P.S.I.	25 P.S.I.
VT 3-30 SVC	500,000	5-90 P.S.I.	30 P.S.I.
VT 2½-30 SVC	400,000	5-90 P.S.I.	25 P.S.I.
VT 2½-24 SVC	500,000	5-90 P.S.I.	30 P.S.I.
BP 2512 SVC	400,000	5-90 P.S.I.	25 P.S.I.



**IMPORTANT WARNINGS:**

**DO NOT OPERATE THIS EQUIPMENT IF:**

- You are subject to seizures, loss of consciousness, or fainting.
- You have been drinking alcohol, using illicit drugs, or prescription drugs that might effect your judgment or balance.
- You have not read or do not understand the operator’s manual.
- You are not capable of safely operating this type of equipment.

**DO NOT ALLOW CHILDREN TO OPERATE THIS EQUIPMENT.**

**FOR YOUR SAFETY!**

If You Smell Gas:

1. Shut off gas to the device.
2. Extinguish any open flame.
3. Check the device for leaks using soapy water.
4. DO NOT attempt to relight the device until leaks are repaired and there is no gas smell

DO NOT use this device in areas where gasoline or other liquids having flammable vapor are stored or used.

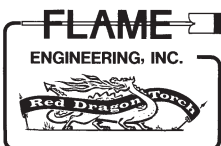

PO Box 577 • 230 W. Hwy 4  
 LaCrosse, Kansas 67548  
 785-222-2873 • FAX 785-222-3619  
 Toll Free 800-255-2469  
 www.FlameEngineering.com

EPA Est. 092521-KS-1  
 VT-MAN-10-2016

# Assembly Instructions:

## Assembly Instructions For Torch Kits With a Standard Flame Adjusting Valve.

*Note: Unpack and inspect for damage.*

1. Using the **thread compound** capsule supplied with torch kit, connect the male end of the adjusting needle valve to the female threaded end of the torch handle. Tighten securely.
2. Using **thread compound**, connect male end of the hose to the female end of the adjusting needle valve. Tighten securely.
3. Using **thread compound**, connect the female end of the hose to the 1/4" male end of the P-3200W P.O.L. Tighten securely.

## Assembly Instructions For SVC Torch Kits With a Squeeze Valve and Handle.

*Note: Unpack and inspect for damage.*

1. Using the **thread compound** capsule supplied with torch kit, connect one end of the male adaptor to the torch and tighten securely.
2. Using **thread compound**, connect the squeeze valve with adjustable pilot to the other end of the male adaptor. Tighten securely.
3. Using **thread compound**, connect the handle grip to the squeeze valve with adjustable pilot. Tighten securely.
4. Using **thread compound**, connect male end of the hose to the female end of the handle grip. Tighten securely.
5. Using **thread compound**, connect the female end of the hose to the 1/4" male end of the P-3200W P.O.L. Tighten securely.

### Parts List Diagram for Models: • VT 3-30 C • VT 1/2-30 C • VT 1/2-24 CE

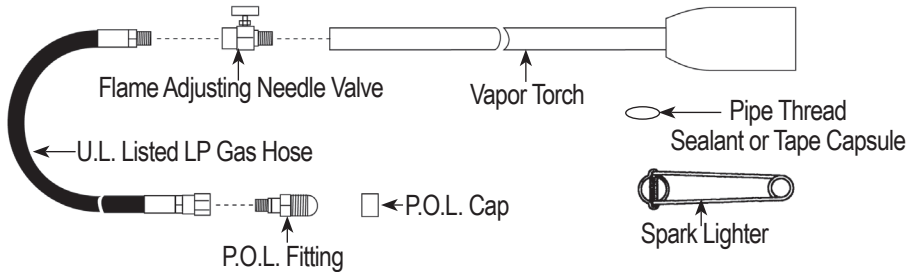

### Parts List Diagram for Models: • VT 3-30 SVC • VT 2 1/2-30 SVC • VT 2 1/2-24 SVC

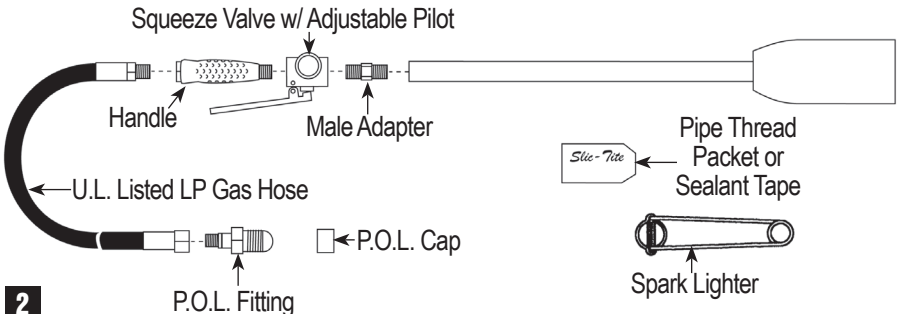

## Red Dragon Back Pack Tank Mounting Instructions For Models: • BP2512C • BP2512SVC

1. Place Bottom Tank Ring onto Bottom Tank Mounting Bracket.
2. Line up one of the large holes on the Top Tank Ring with the hole on the Top Tank Mounting Bracket on the back pack. Secure with bolt, fender washer and wing nut as shown.

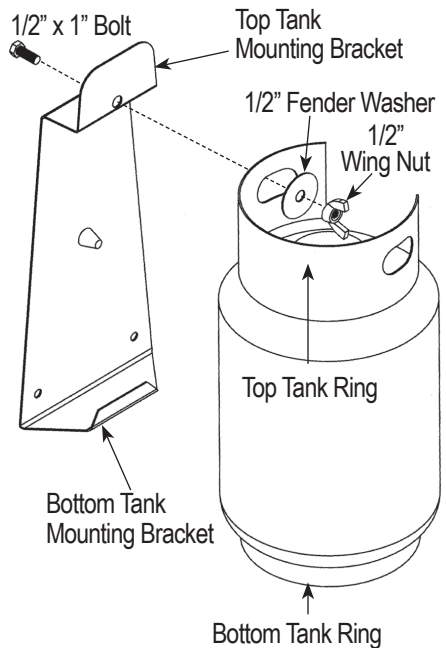

### Connecting To The Supply Cylinder:

The propane supply cylinder used with this torch should be no less than 20 lb. capacity (except for the BP 2512 C and BP 2512 SVC) and must be designed, fabricated, tested and marked in accordance with regulations of the U.S. Department of Transportation, the Canadian Transport Commission or the Interstate Commerce Commission. Supply cylinders must be arranged to provide for vapor withdrawal from the operating cylinder.

1. Inspect the nut/nipple of the P.O.L. connection on the LP-Gas hose. Check for dents or physical damage. The O-ring should be present on nipple fitting. If damage is evident, call for replacement parts.
2. Be certain the supply cylinder valve is fully turned off. Remove the protective plastic plug from the cylinder valve outlet connection.
3. Connect the P.O.L. nut/nipple fitting on the hose to the propane supply cylinder by turning the left hand threaded P.O.L. nut counter clockwise into the cylinder valve outlet. Snug the connection tight with a wrench. **DO NOT OVER TIGHTEN.**
4. Slowly open the cylinder valve 1/4 of a turn. Check all LP-gas connections for leaks using soapy water or suitable leak detection solution. **DO NOT USE MATCHES OR OPEN FLAME TO CHECK FOR LEAKS.** Do not attempt to operate the torch if there is evidence of a leak or at any time the odor of gas is detected.

## Safety Check List:

- Gloves should be used at all times. Long sleeves, long pants & boots are recommended.
- Use only vapor torches on cylinders equipped with vapor withdrawal valves.
- Secure cylinders in a level, upright position. Do not invert or lay cylinders on their sides.
- Do not apply flame to cylinders to check for leaks or to increase gas pressure.
- Keep torches, open flame and sources of ignition away from cylinders, regulators and hose.
- Do not operate torches or any equipment if the odor of LP-Gas is evident. Immediately shut off all valves and, using soapy water, check all equipment for leaks.
- Cylinder valves must be protected. Do not hoist a cylinder by the valve.
- Do not leave the torch unattended while in operation.
- Maintain a fire watch for at least 2 hours.
- Do not stand or prop the torch on the burner end while in operation.
- This equipment is for outdoor use only with adequate ventilation.
- Have a type ABC fire extinguisher on the job site, easily accessible to the person operating the torch.

## Start Up Safety Check List:

- Visually inspect all parts of the torch equipment for damage and wear. If the hose shows excessive abrasion or wear, or if the hose is cut, replace it before operating the torch. Replace torch hose assembly with test laboratory listed LP-Hose, 350 P.S.I. working pressure.
- Using a soapy water solution, check all connections and fittings for leaks.  
**DO NOT USE A MATCH OR OPEN FLAME TO TEST FOR LEAKS.**
- Check LP cylinders for dents, damage to collar, damage to valve, or corroded foot ring. Do not use damaged cylinder. Know if you are using liquid or vapor withdrawal. **USE ONLY VAPOR WITHDRAWAL CYLINDER WITH THE VT 3-30 C, VT 2<sup>1</sup>/<sub>2</sub>-30 C, VT 2<sup>1</sup>/<sub>2</sub>-24 CE, BP 2512 SVC, VT 3-30 SVC, VT 2<sup>1</sup>/<sub>2</sub>-30 SVC, VT 2<sup>1</sup>/<sub>2</sub>-24 SVC AND BP 2512 SVC TORCH KITS.**
- For outdoor use only.
- Check operation of valve and other adjustable parts.

## WARNING:

Use extreme caution at all times. **You are using an intense open flame.** This torch produces an extremely hot and nearly invisible flame. Read and follow the Safety Check List and Daily Equipment Check List before attempting to operate this torch.

## CAUTION

- Propane is heavier than air which can cause it to accumulate in low areas. Be certain all areas are well ventilated.
- Propane has a distinct ODOR. If you smell it, IMMEDIATELY discontinue work, extinguish all flames, locate the leak and correct it, ventilate area before lighting torch.
- Use extreme caution at all times. This device has an intense open flame. Disregard of safe practices can result in severe fire damage, personal injury, or possible death.
- Never direct torch flame toward any person, animal, flammable surface or material.

## Important Note:

All Red Dragon® torch kits are equipped with an excess flow safety device located in the P-3200W Soft Nose Excess Flow POL or P-W795 Hand Tighten Excess Flow POL

### If you experience a low flame upon start up, follow these instructions

1. With everything off and closed (tank and needle valve) ***SLOWLY*** crack the knob of your propane tank about 1/8 to 1/4 of a turn. This will provide plenty of propane flow to provide a large usable flame while using your torch kit. You will not need to turn the propane tank on any further.
2. **WAIT 10 seconds** for the propane to fill the hose.
3. ***Slowly*** crack your adjusting needle valve about 1/4 of a turn just until you hear gas passing through the torch kit.
4. Proceed to light the torch with the spark lighter.
5. You can turn your torch kit up or down using the adjusting needle valve. **If you have a squeeze valve on your unit, be sure to depress and release the lever as slowly as possible so as to not engage the safety P.O.L. valve.**

If you find that you are only getting a weak flame, shut off tank, wait for flame to go out, turn off needle valve, wait :30 and try again slower.

## Important Safeguards:

When using torches, basic safety precautions should always be followed:

### **A. READ ALL INSTRUCTIONS.**

- B. Before using, check all parts for proper function and damage to components parts.
- C. Do not use this torch to heat, mold or bend plastic sheets, moulding or tubing.
- D. Hidden areas such as behind walls, ceilings, floors, soffit boards and other panels may contain flammable materials that could be ignited by the heat gun when working in these locations. The ignition of these materials may not

be readily apparent and could result in property damage and injury to persons.

When working in these locations, keep the torch moving in a back-and-forth motion. Lingering or pausing in one spot could ignite the panel or the material behind it.

E. Do not use this torch to remove paint (if the torch can be used to remove paint, items (F) and (G) below shall be used.

F. **WARNING:** Extreme care should be taken when stripping paint. The peelings residue and vapors of paint may contain lead, which is poisonous. Any pre-1977 paint may contain lead and paint applied to homes prior to 1950 is likely to contain lead. Once deposited on surfaces, hand to mouth contact can result in the ingestion of lead. Exposure to even low levels of lead can cause irreversible brain and nervous system damage; young and unborn children are particularly vulnerable. Before beginning any paint removal process you should determine whether the paint you are removing contains lead. This can be done by your local health department or by a professional who uses a paint analyzer to check the lead content of the paint to be removed. **LEAD-BASED PAINT SHOULD ONLY BE REMOVED BY A PROFESSIONAL AND SHOULD NOT BE REMOVED USING A TORCH.**

G. Persons removing paint should follow these guidelines:

1. Move the work piece outdoors. If this is not possible, keep the work area well ventilated. Open the windows and put an exhaust fan in one of them. Be sure the fan is moving the air from inside to outside.
2. Remove or cover any carpets, rugs furniture, clothing, cooking utensils and air ducts.
3. Place drop cloths in the work area to catch any paint chips or peelings. Wear protective clothing such as extra work shirts, overalls and hats.
4. Work in one room at a time. Furnishings should be removed or placed in the center of the room and covered. Work areas should be sealed off from the rest of the dwelling by sealing doorways with drop cloths.
5. Children, pregnant or potentially pregnant women and nursing mothers should not be present in work area until the work is done and all clean up is complete.
6. Wear a dust respirator mask or a dual filter (dust and fume) respirator mask which has been approved by the Occupational Safety and health Administration (OSHA), the National institute of Safety and Health (NIOSH), or the United States Bureau of Mines. These masks and replaceable filters are readily available at major hardware stores. Be sure the mask fits. Beards and facial hair may keep masks from sealing properly. Change filters often. **DISPOSABLE PAPER MASKS ARE NOT ADEQUATE.**
7. Use caution when operating the heat gun. Keep the heat moving, as excessive heat will generate fumes, which can be inhaled by the operator.
8. Keep food and drink out of the work area. Wash hands, arms and face and rinse mouth before eating or drinking. Do not smoke or chew gum or tobacco in the work area.
9. Clean up all removed paint and dust by wet mopping the floors. Use a wet cloth to clean all walls, sills and any other surface where paint or dust is clinging. **DO**

NOT SWEEP, DRY DUST OR VACUUM. Use a high phosphate detergent or trisodium phosphate (TSP) to wash and mop areas.

10. At the end of each work session put the paint chips and debris in a double plastic bag, close it with tape or twist ties and dispose of properly.

11. Remove protective clothing and work shoes in the work area to avoid carrying dust into the rest of the dwelling. Wash work clothes separately. Wipe shoes off with a wet rag that is then washed with the work clothes. Wash hair and body thoroughly with soap and water.

## H. SAVE THESE INSTRUCTIONS.

### Lighting Instructions:

#### How to Properly Start Your torch Kit.

1. Starting with everything off and closed (Propane tank and needle valve) ***SLOWLY*** crack the knob of your propane tank about 1/8 to 1/4 of a turn. This will provide plenty of propane flow, depending on the level of propane in your tank, to provide a large usable flame while using your torch kit. You will not need to turn the propane tank on any further.
2. Next, you need to ***WAIT 10 seconds*** for the propane to fill the hose.
3. Then ***slowly*** crack your adjusting needle valve about 1/4 of a turn just until you hear gas passing through the torch kit.
4. Then proceed to light the torch with a spark lighter. The spark lighter is used by squeezing the unit, causing the flint to rub together, creating a spark.
5. You can turn your torch kit up or down using the adjusting needle valve. If you have a squeeze valve on your unit, be sure to depress and release the lever as slowly as possible so as to not engage the safety P.O.L. valve.

Following this procedure will prevent the safety valve from engaging and prohibiting your use. If you find that you have turned your kit on too quickly and are only getting a weak flame upon start up, shut off tank, wait for flame to go out, turn off needle valve, wait :30 and try again slower.

#### Lighting Instructions For SVC Torch Kits With a Squeeze Valve and Handle

1. Slowly open the LP-Gas cylinder valve. Check all connections for leaks with a leak detection solution, such as soapy water. Leaks will be indicated by forming bubbles around the source. Allow one minute for bubbles to appear. Repair all leaks and test for leaks prior to lighting torch.
2. Familiarize yourself with the functions of the squeeze valve operations. The round knob, marked with arrows “off” and “on,” is the adjustment valve for lighting the torch and adjusting the pilot flame. Once the desired pilot flame is achieved, the squeeze handle is depressed to give the required working flame pattern.
3. Open the flame adjusting valve (the round knob) 1/8 turn or until a small amount of gas is heard escaping. Using a flint lighter, ignite the torch. DO

NOT PLACE YOUR HAND OR ANY PART OF YOUR BODY IN THE PATH OF THE BURNER WHILE LIGHTING OR OPERATING THE TORCH. DO NOT USE MATCHES OR CIGARETTE LIGHTER TO IGNITE THE TORCH.

4. Adjust the size of the pilot flame by using the flame adjusting valve. Adjust to a low flame that will keep the torch burning in existing conditions, a small flame is usually adequate. Depress the squeeze vavle to achieve full flame.

## **Torch Shut-Off:**

1. Close the LP-Gas cylinder valve.
2. Allow the gas to burn out of hose. After the flame is no longer visible, turn the flame adjusting valve to the closed or “off” position. TO RESTART follow lighting instructions.

## **Disconnecting From The Supply Cylinder:**

1. Be certain supply cylinder valve is turned off.
2. Disconnect the P.O.L. nut/nipple fitting on the LP hose to the propane supply.
3. Replace the protective plastic plug into the cylinder valve outlet.

## **Storage:**

Never attempt to store the torch while it is hot. When the torch is stored indoors, the connection between the LP-Gas supply cylinder and the torch must be disconnected and the cylinder removed form the torch and stored in accordance with Chapter 5 of ANSI/NFPA 58, the standard for storage and handling of liquefied petroleum gases. Do not store the torch in locations where it may be damaged.

### **WARNING**

The gas supply hose shall be protected from traffic, building materials and contact with hot surfaces during use and while in storage.

## **Maintenance:**

- Surfaces of the torch may be cleaned with soap or detergent and water solutions. Do not use petroleum-based cleaners to clean any components of the torch or the torch body.
- Remove any debris and combustibile material from the torch. The torch must be kept clear and free from combustibile materials, gasoline and other flammable vapors and liquids.
- The supply hose assembly shall be visually inspected prior to each torch use. If there is excessive abrasion or wear , or the hose is cut, it must be replaced prior to the torch being put into operation. The replacement hose assembly shall be specified by Flame Engineering, Inc. Contact Flame Engineering for further information.

## For More Information:

Consult your local LP Dealer, Flame Engineering, NPGA, or NFPA Pamphlet 58. This information is provided as a general guide for safe LP-Gas use and in no way constitutes a complete safety program.

## Troubleshooting Your Torch Kit Operation:

For more info go to [www.flameengineering.com](http://www.flameengineering.com)

### **I have only a weak/wimpy flame?**

You are probably turning on your propane tank and torch kit too quickly. There is a safety valve located in the P.O.L. fitting that connects your hose to your propane tank. This feature is there to restrict propane in the event of an accident such as the hose being cut or damaged. If the kit is turned on too quickly the safety valve is activated and will restrict the flow of propane resulting in a very small, flickering, unusable flame. See page 5 for instructions on properly starting and operating your torch kit.

### **Last time I used my torch kit it worked great, now it will not light?**

There is an orifice located inside your torch that may be plugged. In the Mini Dragon™ torch, there is an orifice at the bottom of the torch where the flame comes out, as well as in the fitting that screws into your handle. In other torch kits, the orifice is located at the bottom of the torch only. The orifice is the pin sized hole in the middle of the fitting. If this hole is restricted, the propane cannot properly flow through the torch. With the torch kit turned off and the hose disconnected from the propane tank, locate the orifice and clear area of debris such as cob webs, rust and dirt. You may use a small piece of wire, or compressed air to clear the orifice. NEVER use water as this may disrupt the performance of your torch kit. See also instructions for properly starting your torch kit.

### **I am experiencing flame out when I am trying to flame my weeds.**

If your flame goes out when you try to flame your weeds, you may be holding the torch too close to the ground and/or weeds. Fire needs oxygen to burn so it is easy to snuff out the flame if you get too close, especially for small flame weeding models. Try holding your torch kit farther away.

### **What is the small white pill/packet for?**

This is your pipe thread sealant to be applied to all connections of your propane torch kit, except the P.O.L. Excess Flow valve to your propane tank. See your instruction manual for instructions on properly testing your torch kit for leaks. See page \_\_\_ for assembly instructions.

### **My hose P.O.L. fitting does not seem to fit into the propane tank?**

The fitting that screws into the propane tank (P.O.L. Excess Flow Valve) has a left hand thread therefore will screw into the tank to the left, instead of most threads that screw to the right. It will screw into the inside of the propane tank valve. This P.O.L. fitting will fit any *standard* propane tank, however may not screw all the way into the tank depending on the style of tank that you have. Be sure that the P.O.L. fitting fits snug into the propane tank if there are threads exposed. We recommend tightening the connections to the tank with a wrench. See page 2 for assembly instructions.

## Flame Weeding 101:

How to correctly flame your weeds.

When flame weeding, the most effective method is to catch weeds early, from 1-4 inches. At this small stage, flaming is nearly 100% effective, whereas weeds over 4 inches are more difficult to kill without an extended dose of heat.

You only want to *heat* the leaves of the weed in need of removal. If the weed is “burned to a crisp”, that plant will shut down its photosynthesis system (process in which a plant produces its energy to survive and thrive”, only to grow back from the unharmed root a few days later. The flaming process is a slow kill. By *heating or steaming* the leaves, you disrupt the structure of the cells (*by boiling the moisture*) therefore killing the plant and the roots from which it grows. It takes only a few days for weeds to dry up.

By *destroying* cell structure in the plant leaf, the weed will no longer put energy toward growth so even on big weeds you will see stunting effect or even a kill, depending on how established the root system is and how long the plant was exposed to heat.

On smaller weeds a slow walk is usually the best pace - just a split second of heat should kill unwanted weeds and grasses - *you don't need to burn them to a crisp*. By nature, some grasses will return following a flaming. Repeat applications, however, will usually do the trick. For best results, increase exposure to the heat if weeds are wet from dew. Water on the leaves acts as insulation and decreases cell damage unless exposure time is increased.

It is important to remember when flaming in and around desirable plants *that heating those leaves can cause damage as well*, so be careful around flowers and shrubs - particularly evergreens. **Conifers are very flammable and should be avoided. Poison ivy, oak or any poisonous plant should be avoided also - the smoke from flamed leaves will cause a rash to your skin, eyes and lungs!**

What's the best advice we can give you? If in doubt, don't. Always allow a safe distance between the flame and desirable plants, shrubs and trees. Always keep a fire extinguisher and water supply close in case of an emergency.